

6.5 X 8.0 & 8.4 X 9.0 INSERTS

FITS 84/90 U-FRAME

Standard Solid Insert (6.5 X 8.0)		
Catalog #	A	B
84/90 SSU 221	1.377	1.377
84/90 SSU 222	1.377	1.877
84/90 SSU 223	1.877	1.377
84/90 SSU 224	1.877	1.877
84/90 SSU 225	1.877	2.377
84/90 SSU 226	2.377	1.877
84/90 SSU 227	2.377	2.377
84/90 SSU 228	2.377	2.877
84/90 SSU 229	2.877	2.377
84/90 SSU 230	2.877	2.877

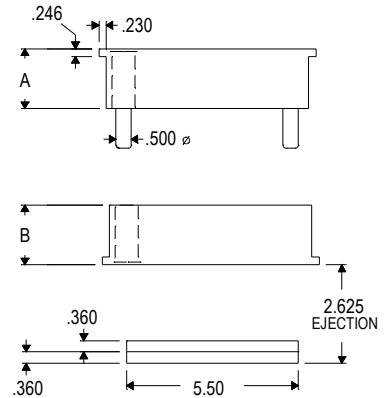
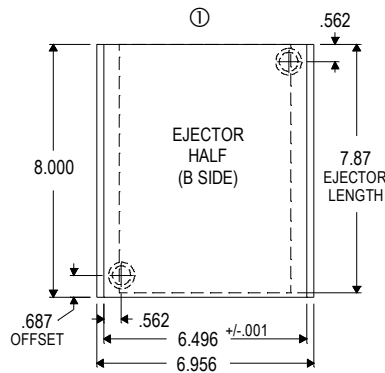

Standard Laminated Insert (6.5 X 8.0)				
Catalog #	A	A2	B2	B
84/90 SLU 281	1.877	0.877	0.877	1.877
84/90 SLU 282	1.877	0.877	1.377	2.377
84/90 SLU 283	2.377	1.377	0.877	1.877
84/90 SLU 284	2.377	1.377	1.377	2.377
84/90 SLU 285	2.377	1.377	1.877	2.877
84/90 SLU 286	2.877	1.877	1.377	2.377
84/90 SLU 287	2.877	1.877	1.877	2.877

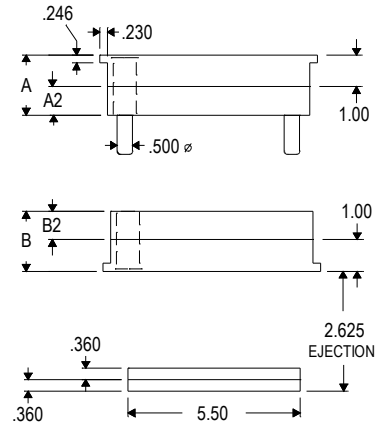
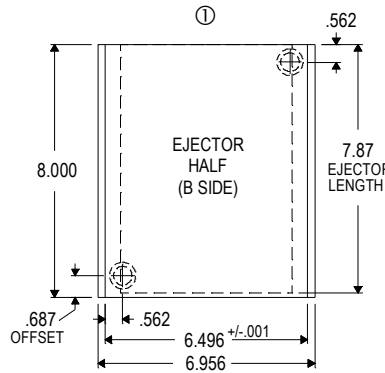

T-Style Laminated Inserts are shipped with loose ear plates

T-Style Laminated Insert (8.4 X 9.0)				
Catalog #	A	A2	B2	B
84/90 TLU 201	1.500	0.750	1.250	2.000
84/90 TLU 202	1.750	1.000	1.000	1.750
84/90 TLU 203	1.750	1.000	1.500	2.250
84/90 TLU 204	2.000	1.250	1.250	2.000
84/90 TLU 205	2.250	1.500	1.000	1.750
84/90 TLU 206	2.250	1.500	1.500	2.250
84/90 TLU 207	2.625	1.875	1.875	2.625

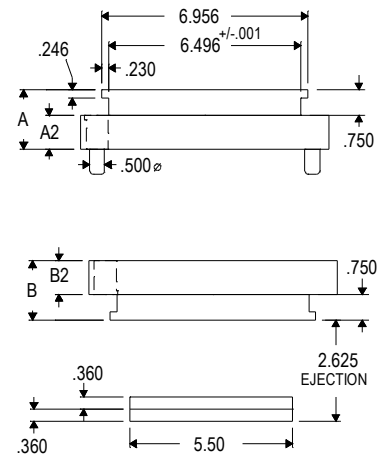
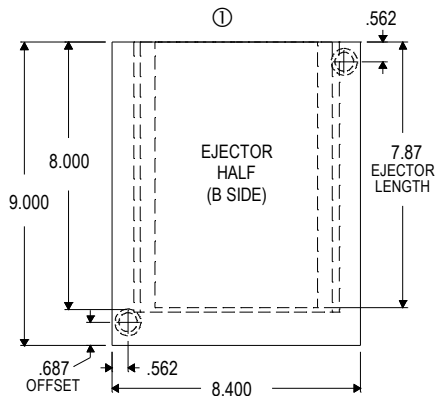

① Clamp Side

"A" & "B" dimensions are supplied .004" to .007" oversize at parting line unless otherwise specified.