

7.0 X 14.9 & 9.9 X 14.9 INSERTS

FITS 10/16 U-FRAME

Standard Solid Insert (7.0 X 14.9)		
Catalog #	A	B
10/16 SSU 221	1.377	1.377
10/16 SSU 222	1.377	1.877
10/16 SSU 223	1.877	1.377
10/16 SSU 224	1.877	1.877
10/16 SSU 225	1.877	2.377
10/16 SSU 226	2.377	1.877
10/16 SSU 227	2.377	2.377
10/16 SSU 228	2.377	2.877
10/16 SSU 229	2.877	2.377
10/16 SSU 230	2.877	2.877

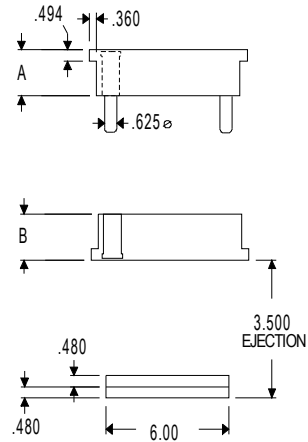
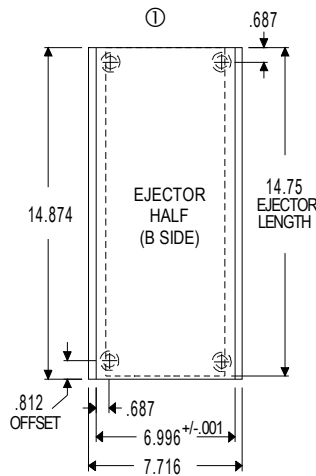

Standard Laminated Insert (7.0 X 14.9)				
Catalog #	A	A2	B2	B
10/16 SLU 281	1.877	0.877	0.877	1.877
10/16 SLU 282	1.877	0.877	1.377	2.377
10/16 SLU 283	1.877	0.877	1.877	2.877
10/16 SLU 284	2.377	1.377	0.877	1.877
10/16 SLU 285	2.377	1.377	1.377	2.377
10/16 SLU 286	2.377	1.377	1.877	2.877
10/16 SLU 287	2.877	1.877	0.877	1.877
10/16 SLU 288	2.877	1.877	1.377	2.377
10/16 SLU 289	2.877	1.877	1.877	2.877

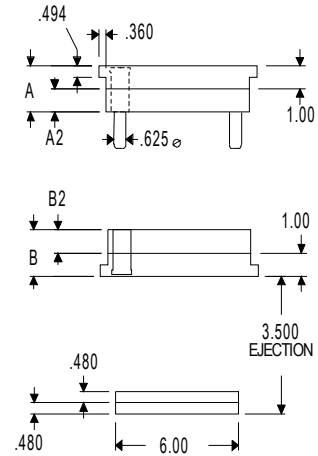
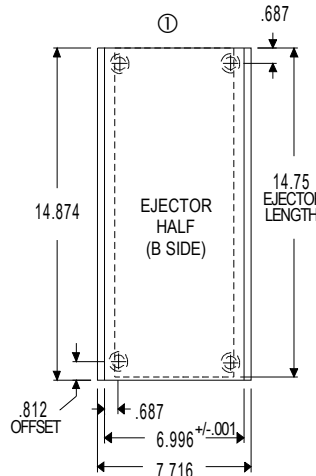

T-Style Laminated Inserts are shipped with loose ear plates

T-Style Laminated Insert (9.9 X 14.9)				
Catalog #	A	A2	B2	B
10/16 TLU 201	1.877	0.877	0.877	1.877
10/16 TLU 202	1.877	0.877	1.377	2.377
10/16 TLU 203	2.377	1.377	0.877	1.877
10/16 TLU 204	2.377	1.377	1.377	2.377
10/16 TLU 205	2.377	1.377	1.877	2.877
10/16 TLU 206	2.877	1.877	1.377	2.377
10/16 TLU 207	2.877	1.877	1.877	2.877
10/16 TLU 208	2.877	1.877	2.377	3.377
10/16 TLU 209	3.377	2.377	1.877	2.877
10/16 TLU 210	3.377	2.377	2.377	3.377

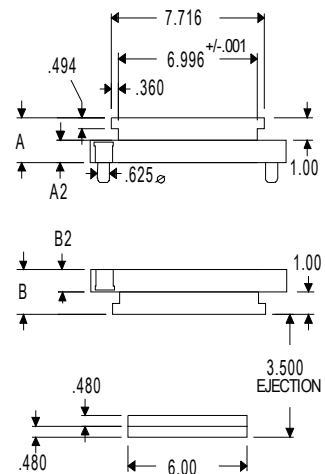
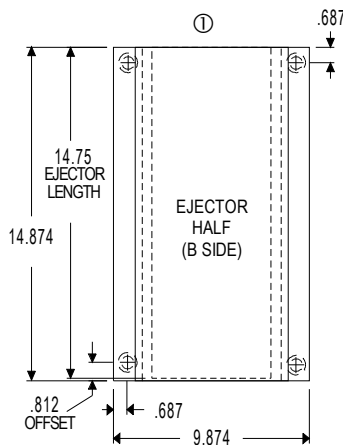

① Clamp Side

"A" & "B" dimensions are supplied .004" to .007" oversize at parting line unless otherwise specified.

Cross Tool & Manufacturing, Inc.
1-800-832-3993
crosstool.com