

5.0 X 5.0 INSERTS

FITS 10/12 H-FRAME and 16/12 DOUBLE H-FRAME

① Clamp Side

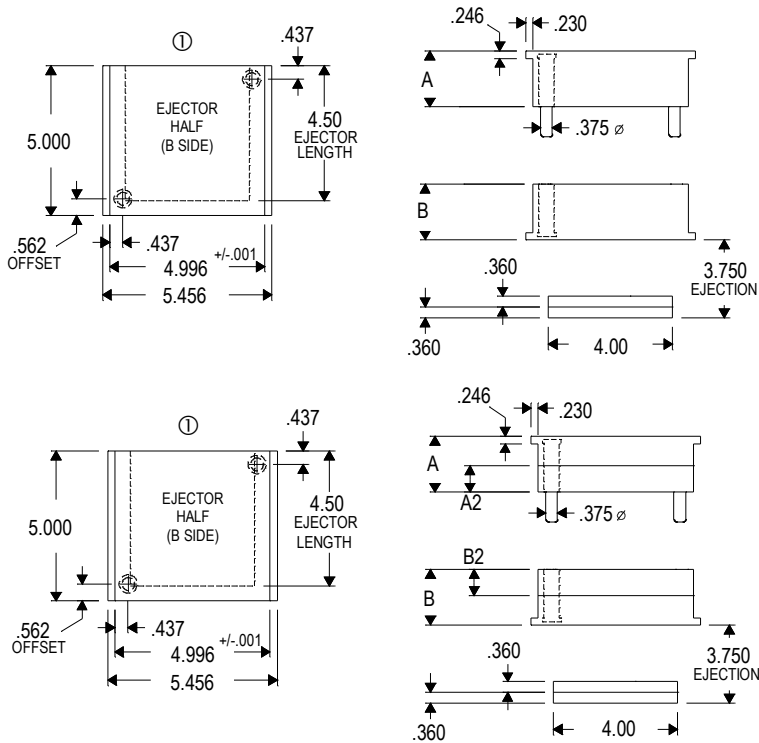

| Standard Solid Insert (5.0 X 5.0) | | |
|-----------------------------------|-------|-------|
| Catalog # | A | B |
| 10/12 SSH 221 | 1.877 | 1.377 |
| 10/12 SSH 222 | 1.877 | 1.877 |
| 10/12 SSH 223 | 1.877 | 2.377 |
| 10/12 SSH 224 | 2.377 | 1.877 |
| 10/12 SSH 225 | 2.377 | 2.377 |

| Standard Laminated Insert (5.0 X 5.0) | | | | |
|---------------------------------------|-------|-------|-------|-------|
| Catalog # | A | A2 | B2 | B |
| 10/12 SLH 281 | 1.877 | 0.877 | 0.877 | 1.377 |
| 10/12 SLH 282 | 1.877 | 0.877 | 0.877 | 1.877 |
| 10/12 SLH 283 | 1.877 | 0.877 | 1.377 | 2.377 |
| 10/12 SLH 284 | 2.377 | 1.377 | 0.877 | 1.877 |
| 10/12 SLH 285 | 2.377 | 1.377 | 1.377 | 2.377 |

5.0 X 8.0 INSERTS

FITS 10/18 H-FRAME and 16/18 DOUBLE H-FRAME

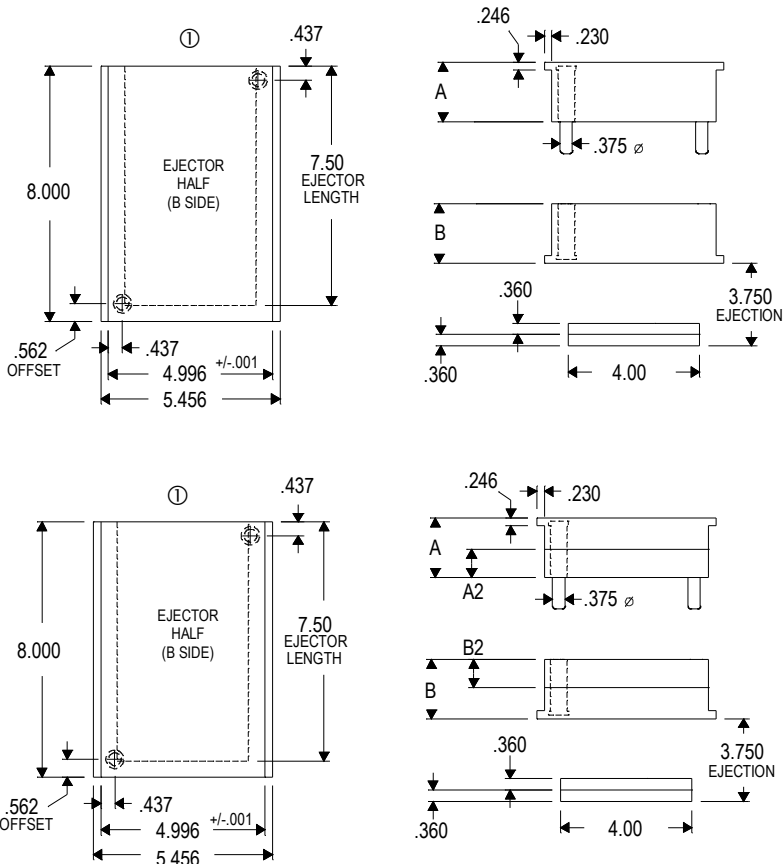

| Standard Solid Insert (5.0 X 8.0) | | |
|-----------------------------------|-------|-------|
| Catalog # | A | B |
| 10/18 SSH 221 | 1.877 | 1.377 |
| 10/18 SSH 222 | 1.877 | 1.877 |
| 10/18 SSH 223 | 1.877 | 2.377 |
| 10/18 SSH 224 | 2.377 | 1.877 |
| 10/18 SSH 225 | 2.377 | 2.377 |
| 10/18 SSH 226 | 2.377 | 2.877 |
| 10/18 SSH 227 | 2.877 | 2.377 |
| 10/18 SSH 228 | 2.877 | 2.877 |

| Standard Laminated Insert (5.0 X 8.0) | | | | |
|---------------------------------------|-------|-------|-------|-------|
| Catalog # | A | A2 | B2 | B |
| 10/18 SLH 281 | 1.877 | 0.877 | 0.877 | 1.377 |
| 10/18 SLH 282 | 1.877 | 0.877 | 0.877 | 1.877 |
| 10/18 SLH 283 | 1.877 | 0.877 | 1.377 | 2.377 |
| 10/18 SLH 284 | 2.377 | 1.377 | 0.877 | 1.877 |
| 10/18 SLH 285 | 2.377 | 1.377 | 1.377 | 2.377 |
| 10/18 SLH 286 | 2.377 | 1.377 | 1.877 | 2.877 |
| 10/18 SLH 287 | 2.877 | 1.877 | 1.377 | 2.377 |
| 10/18 SLH 288 | 2.877 | 1.877 | 1.877 | 2.877 |