

5.0 X 8.0 & 7.85 X 9.0 INSERTS

FITS 08/09 U-FRAME

Standard Solid Insert (5.0 X 8.0)

Catalog #	A	B
08/09 SSU 221	1.377	1.377
08/09 SSU 222	1.377	1.877
08/09 SSU 223	1.877	1.377
08/09 SSU 224	1.877	1.877
08/09 SSU 225	1.877	2.377
08/09 SSU 226	2.377	1.877
08/09 SSU 227	2.377	2.377
08/09 SSU 228	2.377	2.877
08/09 SSU 229	2.877	2.377
08/09 SSU 230	2.877	2.877

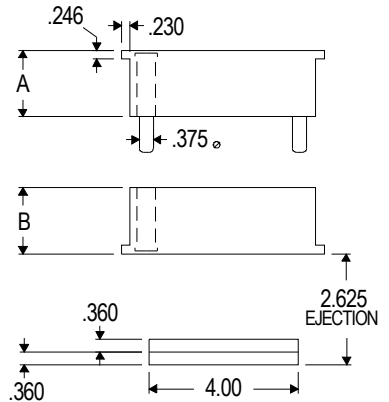
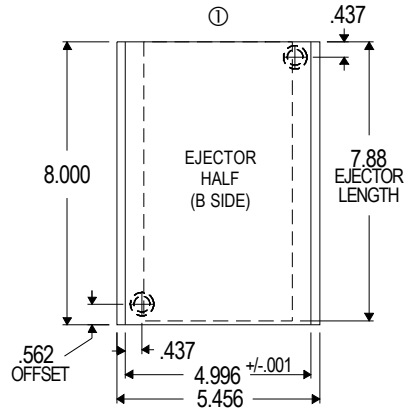

Standard Laminated Insert (5.0 X 8.0)

Catalog #	A	A2	B2	B
08/09 SLU 281	1.377	0.627	0.627	1.377
08/09 SLU 282	1.377	0.627	1.127	1.877
08/09 SLU 283	1.877	1.127	0.627	1.377
08/09 SLU 284	1.877	1.127	1.127	1.877
08/09 SLU 285	1.877	1.127	1.627	2.377
08/09 SLU 286	2.377	1.627	1.127	1.877
08/09 SLU 287	2.377	1.627	1.627	2.377
08/09 SLU 288	2.377	1.627	2.127	2.877
08/09 SLU 289	2.877	2.127	1.627	2.377
08/09 SLU 290	2.877	2.127	2.127	2.877

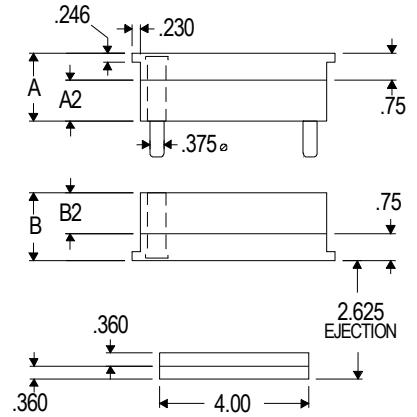
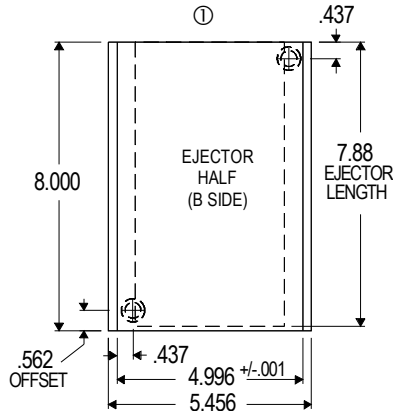

T-Style Laminated Inserts are shipped with loose ear plates

T-Style Laminated Insert (7.85 X 9.0)

Catalog #	A	A2	B2	B
08/09 TLU 201	1.750	1.000	1.000	1.750
08/09 TLU 202	1.750	1.000	1.500	2.250
08/09 TLU 203	2.000	1.250	1.250	2.000
08/09 TLU 204	2.250	1.500	1.000	1.750
08/09 TLU 205	2.250	1.500	1.500	2.250
08/09 TLU 206	2.625	1.875	1.875	2.625

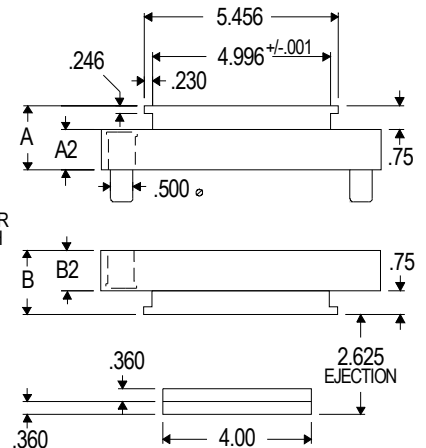
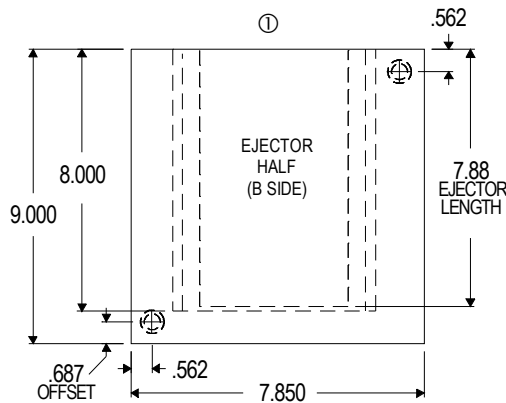

① Clamp Side

"A" & "B" dimensions are supplied .004" to .007" oversize at parting line unless otherwise specified.