

# 10/12 C-XSU-S STRIPPER PLATE INSERT 7.0 X 10.9 FITS 10/12 U-FRAME

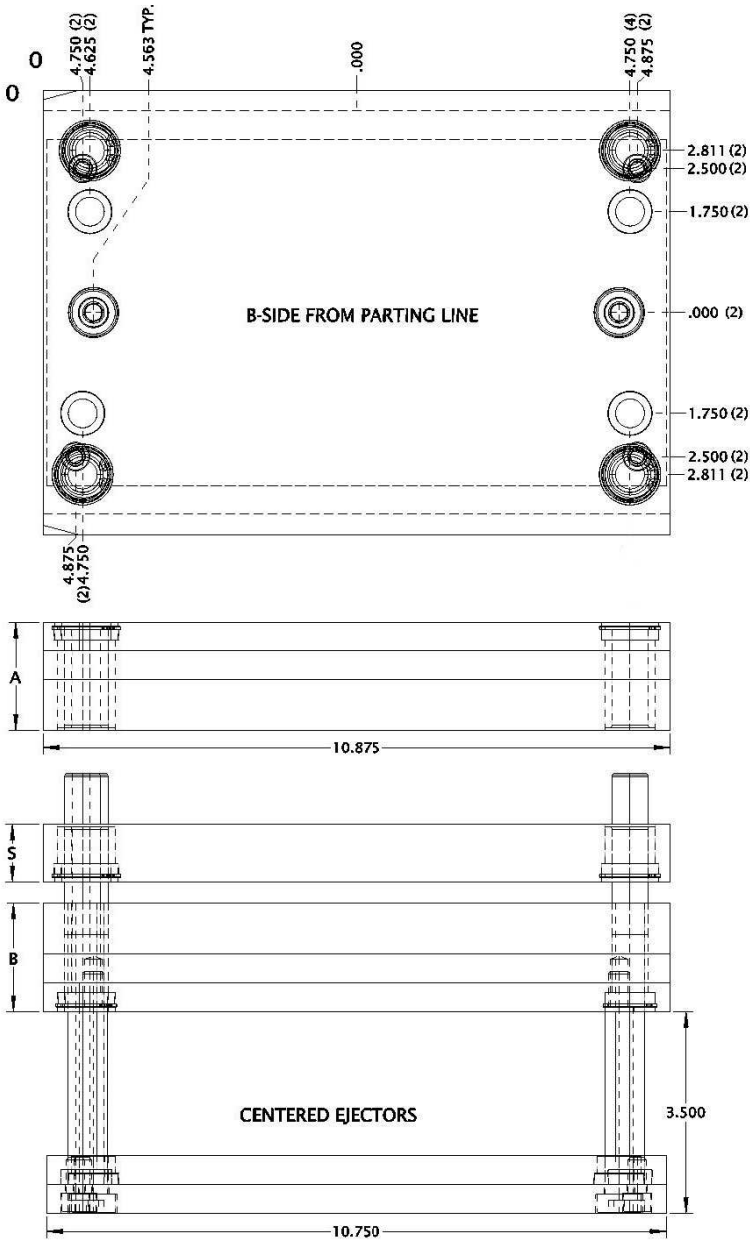

YOUR CHOICES INCLUDE:

- \* ALL THE OPTIONS FOR RETURN PINS, GUIDED EJECTORS OR BLANK EJECTOR PLATES (SEE C-XSU PAGE 22)
- \* ALSO AVAILABLE WITH A LAMINATED B-SIDE

SHOWN WITH SIMPLE GUIDED EJECTION

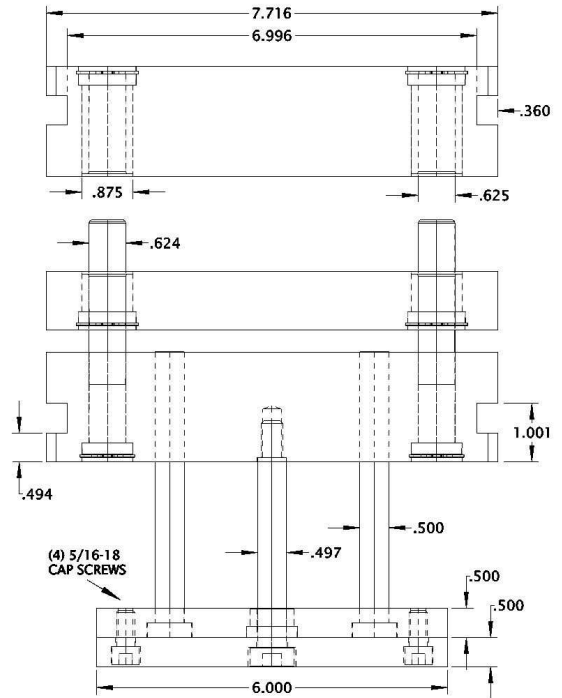

ORDERING EXAMPLES:

10/12 C-XSU-S-005-1  
10/12 C-XSU-S-001-1  
10/12 C-XSU-S-003-1

CUSTOM ORDER EXAMPLES:

10/12 C-SLU-S    10/12 C-XSU-S-2HOLE  
A 1.877            A 1.877  
A2 1.125           S 0.750  
S 1.000            B 2.377  
B2 1.627  
B 2.377

A-PLATES AND B-PLATES CAN BE ORDERED IN ANY COMBINATION OF 1.377, 1.877, 2.377, OR 2.877.

OTHER STRIPPER THICKNESSES ARE ALSO AVAILABLE

CATALOG NUMBER	A	B	S
10/12 C-XSU-S-001	1.877	1.377	1.000
10/12 C-XSU-S-002	1.877	1.877	1.000
10/12 C-XSU-S-003	1.877	2.377	1.000
10/12 C-XSU-S-004	2.377	1.877	1.000
10/12 C-XSU-S-005	2.377	2.377	1.000
10/12 C-XSU-S-006	2.877	2.377	1.000