

C-08/09 POCKETS

REQUIRED INFORMATION

Single Pocket:

- Width of pocket inside the 4.996 width on C-XSU and C-SLU, or 7.85 inch T-plate dimension.
- Length of pocket inside 8 inch ear-plate dimension
- Depth of pocket
- Corner radius (.3115 standard to 1 inch deep)
- Corner radius (.375 standard from 1 to 2 inch deep)
- Center of pocket from middle of ear-plate towards or away from offset leader pin.

Multiple Pocket:

- Width of pockets
- Length of pockets
- Depth of Pockets
- Corner radius (.3115 standard to 1 inch deep)
- Corner radius (.375 standard from 1 to 2 inch deep)
- Location of pocket centers from middle of ear-plate towards or away from offset leader pin.

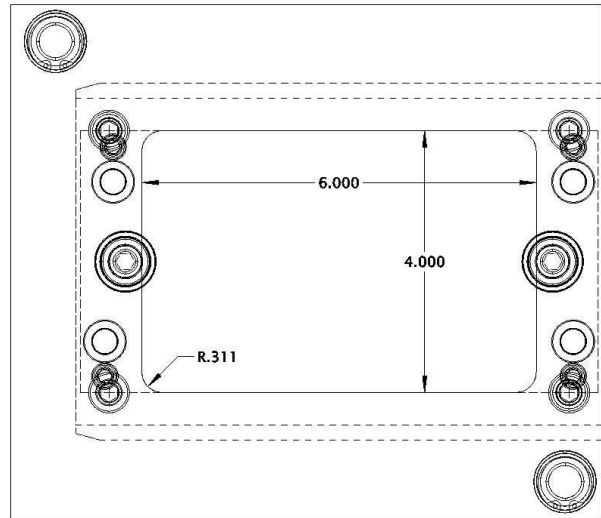

08/09 CTLU laminated pockets
maximum through size

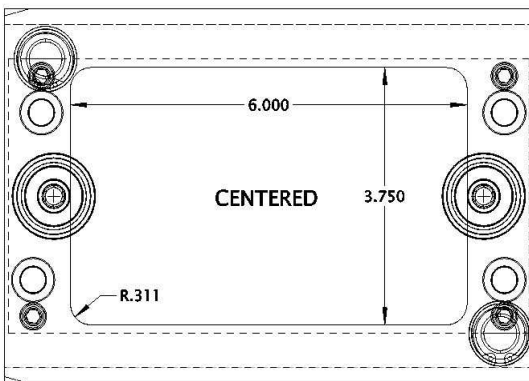

08/09 CXSU solid pockets
maximum size

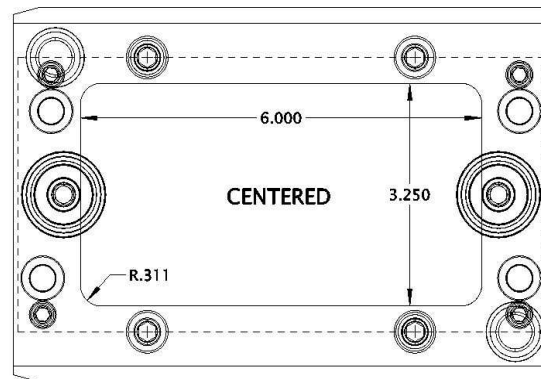

08/09 CSLU laminated pockets
maximum size

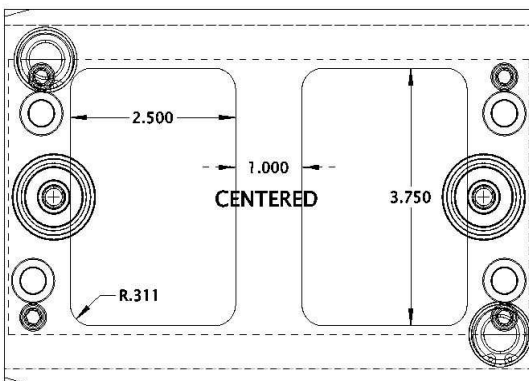

08/09 CXSU solid pockets
maximum size

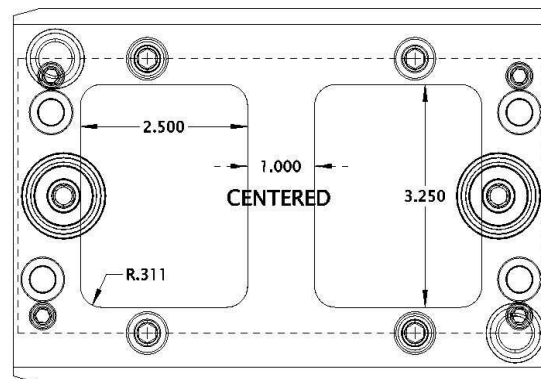

08/09 CSLU laminated pockets
maximum size